



GaN-based UV photodiode

Model **GS-ABC-3535MI**

General Features:

- UVA+UVB+UVC photodiode
- Photovoltaic mode operation
- SMD 3535 ceramic inorganic package
- Good visible blindness
- High responsivity and low dark current



Applications: air purification, water quality measurement

Specifications:

Parameters	Symbol	Value	Unit
Maximum ratings			
Operation temperature range	T_{opt}	-25-85	°C
Storage temperature range	T_{sto}	-40-85	°C
Soldering temperature (3 s)	T_{sol}	260	°C
Reverse voltage	V_{r-max}	-10	V
General characteristics (25 °C)			
Chip size	A	0.22	mm ²
Dark current ($V_r = -1$ V)	I_d	<1	nA
Temperature coefficient (@265 nm)	T_c	0.05	%/°C
Capacitance (at 0 V and 1 MHz)	C_p	3.4	pF
Spectral response characteristics (25 °C)			
Wavelength of peak responsivity	ρ	355	nm
Peak responsivity (at 355 nm)	R_{max}	0.20	A/W
Spectral response range ($R=0.1 \times R_{max}$)	-	210-370	nm
UV-visible rejection ratio ($R_{max}/R_{400\text{ nm}}$)	-	$>10^4$	-

Spectral response

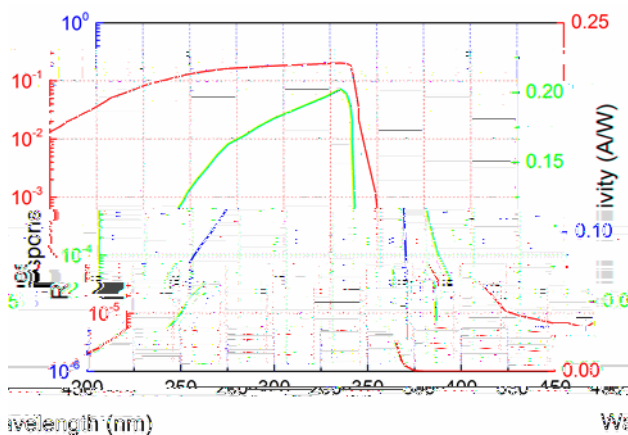

Package dimensions

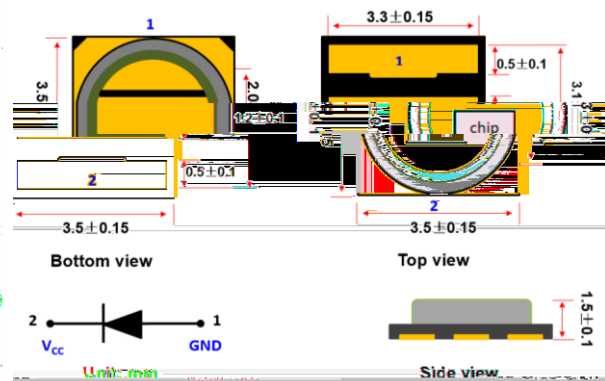



GaN-based UV photodiode

Model GS-ABC-3535MI

Application circuit:

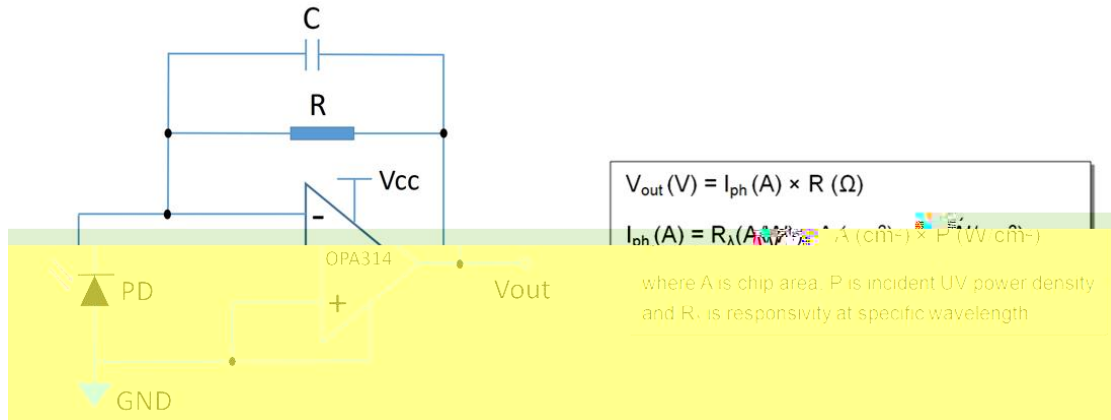

Evaluation circuit board:

A small multifunctional amplifier board for developers to simplify and support application development can be separately provided. The evaluation board with one amplifier channel supports both SMD- and TO-type packaged UV photodiodes supplied by GaNo Opto. Users could select one of the two mounting ports for UV photodiode evaluation, while both ports should not be used at the same time.

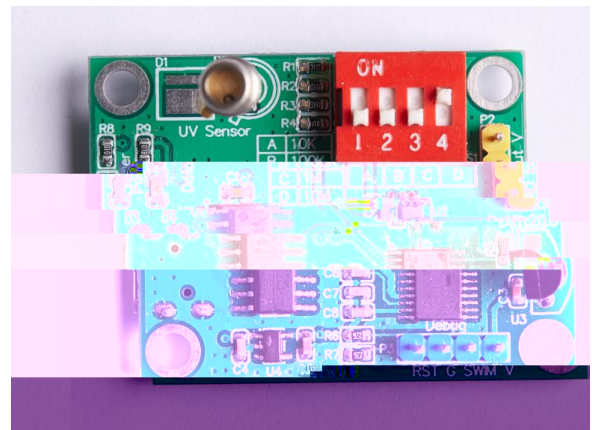

The evaluation board supports measurement range adjustment function via a dip switch.

Different setting of the a dip ion en-USdip> BD5jBT1 > BD1 0rctcent 0 n-Ud(-)-327(a)-325(dip)loa50(coulp)a p